

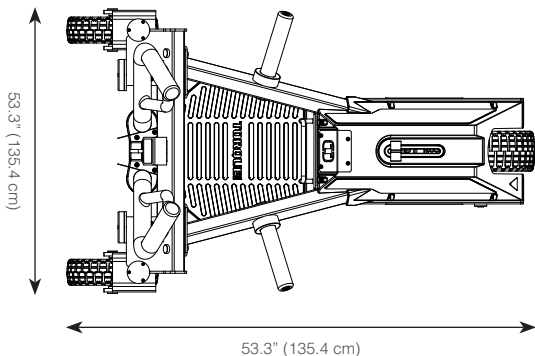

Model number	XTTM3-MPH
Footprint (L x W x H) (Standard)	53.3" x 32.4" x 36.9" (135.4 cm x 82.2 cm x 93.7 cm)
Footprint (L x W x H) (Wheelbarrow)	73.9" x 32.4" x 17.3" (187.7 cm x 82.2 cm x 44.0 cm)
Weight	209 lbs (94.8 kg)
Warranty	10 year frame and welds/1 year parts and finish/90 days grips and optional accessories
Note	Compatible with XTTM3-C Console (sold separately)

TOP VIEW - STANDARD



TOP VIEW - WHEELBARROW

